

**A-TYPE**

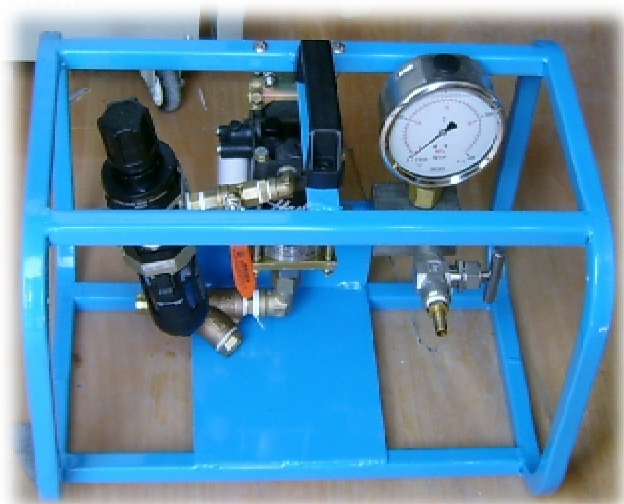

**\*\*\*\* SPECIFICATION \*\*\*\***

- STANDARD MODEL / A/HHW-MS-12
- AIR WORKING PRESSURE / 0.15Mpa ~ 0.6Mpa.
- LIQUID WORKING PRESSURE / 1.2Mpa ~ 7.5Mpa.
- PUMP DRIVEN FLUID / WATER & OIL VG46
- LIQUID PRESSURE CONTROL / AIR REGULATOR.
- AIR REGULATOR CONTROL RAGE / 1.2Mpa ~ 7.5Mpa.
- AIR DRIVEN PUMP M/K / HASKEL®
- FRAME SIZE ( mm ) / W350 X L450 X H350

**※ ACCESSORY LIST ※**

- AIR FILTER REGULATOR( GAUGE부착형 )
- AIR ON/OFF VALVE
- LIQUID INLET LINE FILTER
- MANIFOLD
- PRESSURE GAUGE / 100mm X 100BAR A/T
- DRAIN VALVE

**※OPTION ACCESSORY = DIGITAL GAUGE**

**# PUMP DWG**

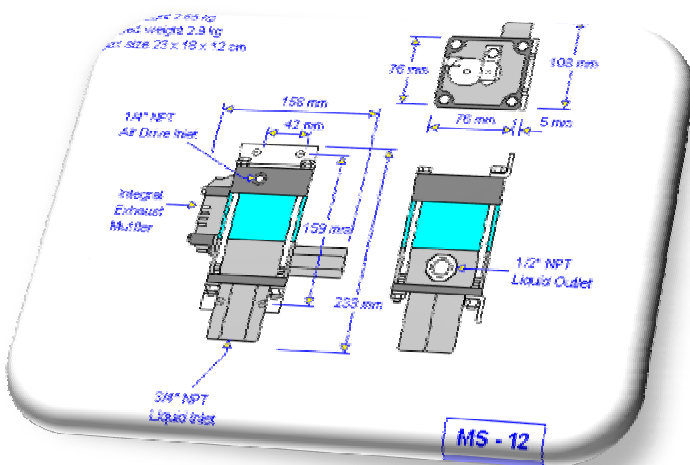

**# PRESSURE & FLOW RAGE**

