

A-TYPE

****** SPECIFICATION ******

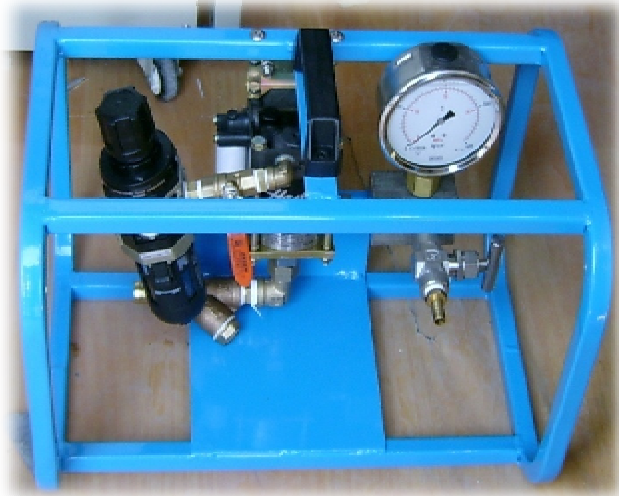

- STANDARD MODEL
/ A/HHW-MS-36
- AIR WORKING PRESSURE
/ 0.15Mpa ~ 0.6Mpa.
- LIQUID WORKING PRESSURE
/ 3.6Mpa ~ 21.6Mpa.
- PUMP DRIVEN FLUID
/ WATER & OIL VG46
- LIQUID PRESSURE CONTROL
/ AIR REGULATOR.
- AIR REGULATOR CONTROL RAGE
/ 3.6Mpa ~ 21.6Mpa.
- AIR DRIVEN PUMP M/K
/ HASKEL®
- FRAME SIZE (mm)
/ W350 X L450 X H350



※ ACCESSORY LIST ※

- AIR FILTER REGULATOR(GAUGE부착형)
- AIR ON/OFF VALVE
- LIQUID INLET LINE FILTER
- MANIFOLD
- PRESSURE GAUGE / 100mm X 250BAR A/T
- DRAIN VALVE

※OPTION ACCESSORY = DIGITAL GAUGE

PUMP DWG

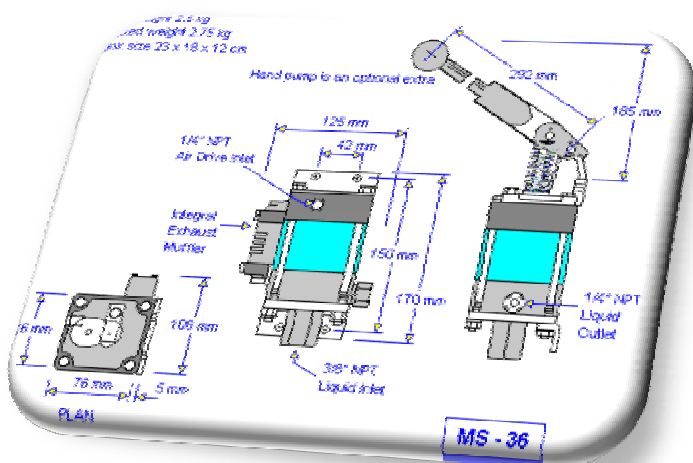

PRESSURE & FLOW RAGE

