

A-TYPE

****** SPECIFICATION ******

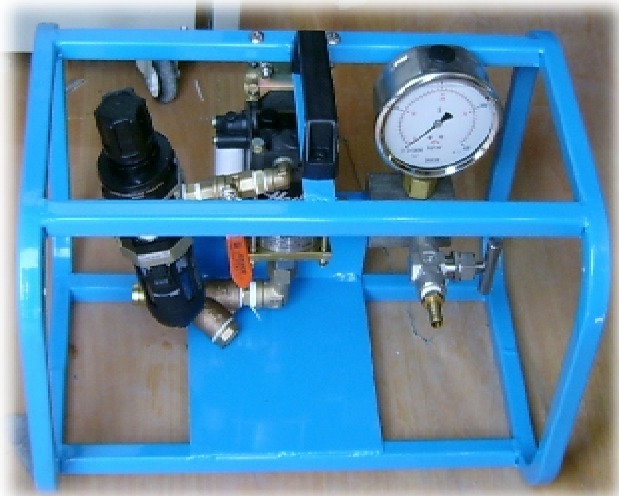

- STANDARD MODEL / A/HHW-MS-71
- AIR WORKING PRESSURE / 0.15Mpa ~ 0.6Mpa.
- LIQUID WORKING PRESSURE / 7.1Mpa ~ 42.6Mpa.
- PUMP DRIVEN FLUID / WATER & OIL VG46
- LIQUID PRESSURE CONTROL / AIR REGULATOR.
- AIR REGULATOR CONTROL RAGE / 7.1Mpa ~ 42.6Mpa.
- AIR DRIVEN PUMP M/K / HASKEL®
- FRAME SIZE (mm) / W350 X L450 X H350



※ ACCESSORY LIST ※

- AIR FILTER REGULATOR(GAUGE부착형)
- AIR ON/OFF VALVE
- LIQUID INLET LINE FILTER
- MANIFOLD
- PRESSURE GAUGE / 100mm X 600BAR A/T
- DRAIN VALVE

※OPTION ACCESSORY = DIGITAL GAUGE

PUMP DWG

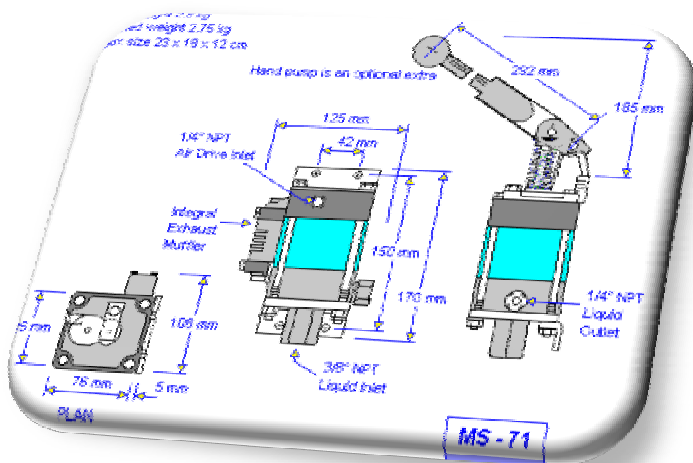

PRESSURE & FLOW RAGE

