

**# BOOSTER DWG**

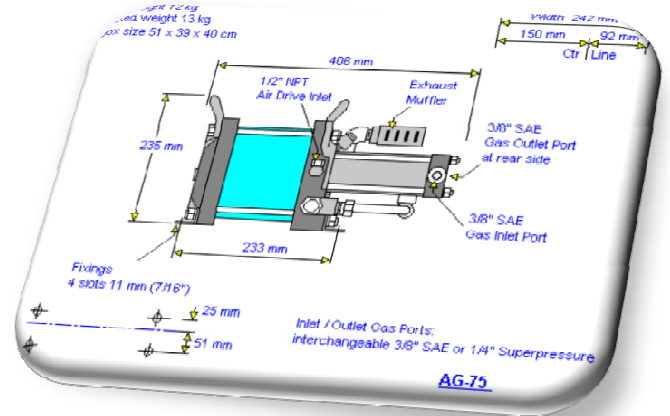

**\*\*\*\* SPECIFICATION \*\*\*\***

- STANDARD GAS BOOSTER MODEL : *HAG-AG-75-P-T500*
- WORKING PRESSURE ( P-1 ) : 40Mpa. ( 400BAR )  
( AIR DRIVEN PRESSURE = 0.6Mpa AIR DRIVEN )
- WORKING PRESSURE ( P-2 ) : 40Mpa. ( 400BAR )  
( GAS CONTROL TYPE : GAS REGULATOR CONTROL )
- MINIMUM GAS INLET PRESSURE : 1.77Mpa. ( 17.7BAR )
- GAS BOOSTER M/K : *HASKEL®*
- PRESSURE & FLOW RAGE ( P=BAR , FL=nl/min )

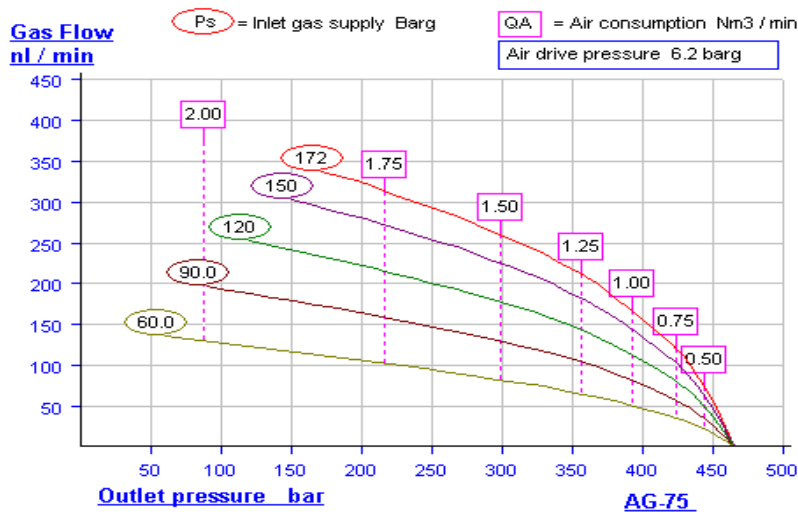

- STANDARD GAS RECEIVER : 500ml STANLESS STEEL
- PRESSURE GAUGE : AIR = 100mm X 1Mpa TYPE = BD  
GAS INLET PRESSURE = 100mm X 15Mpa TYPE = BD  
GAS OUTLET PRESSURE ( P=1 ) = 100mm X 60Mpa TYPE = BD  
GAS OUTLET PRESSURE ( P=2 ) = 100mm X 60Mpa TYPE = BD