

**# BOOSTER DWG**

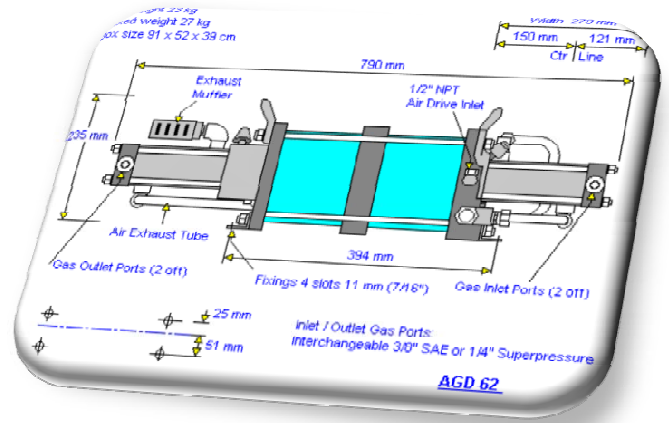

**\*\*\*\* SPECIFICATION \*\*\*\***

- STANDARD GAS BOOSTER MODEL : **HAG-AGD-62-P-T500**
- WORKING PRESSURE ( P-1 ) : **37Mpa. ( 370BAR )**  
( AIR DRIVEN PRESSURE = 0.6Mpa AIR DRIVEN )
- WORKING PRESSURE ( P-2 ) : **37Mpa. ( 370BAR )**  
( GAS CONTROL TYPE : GAS REGULATOR CONTROL )
- MINIMUM GAS INLET PRESSURE : **1.4Mpa. ( 14BAR )**
- GAS BOOSTER M/K : **HASKEL ®**
- PRESSURE & FLOW RAGE ( P=BAR , FL=nl/min )

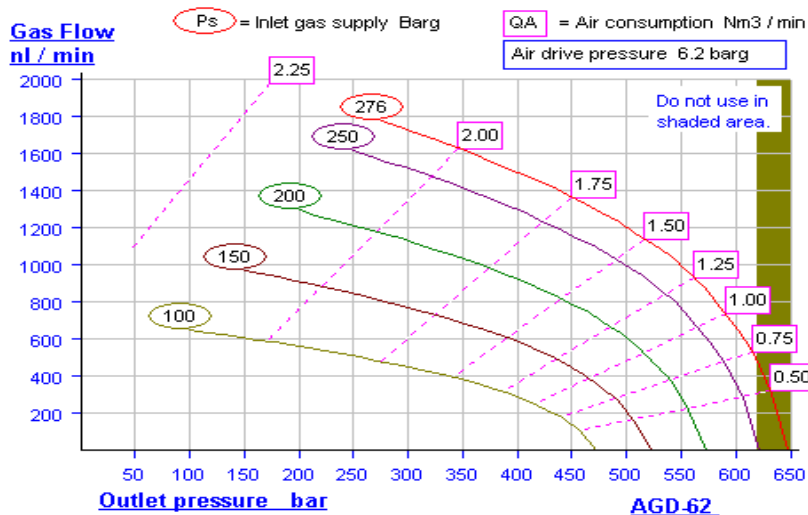

- STANDARD GAS RECEIVER : **500ml STANLESS STEEL**
- PRESSURE GAUGE : AIR = 100mm X 1Mpa TYPE = BD  
GAS INLET PRESSURE = 100mm X 15Mpa TYPE = BD  
GAS OUTLET PRESSURE ( P=1 ) = 100mm X 40Mpa TYPE = BD  
GAS OUTLET PRESSURE ( P=2 ) = 100mm X 40Mpa TYPE = BD