

**# BOOSTER DWG**

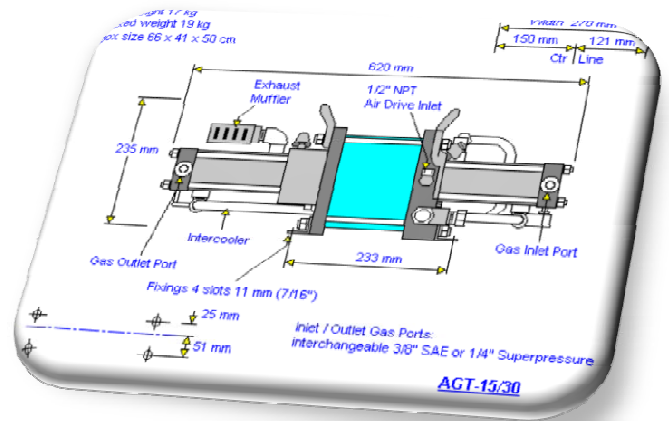

**\*\*\*\* SPECIFICATION \*\*\*\***

- STANDARD GAS BOOSTER MODEL : **HAG-AGT-15/30-P-T500**
- WORKING PRESSURE ( P-1 ) : **18Mpa. ( 180BAR )**  
( AIR DRIVEN PRESSURE = 0.65Mpa AIR DRIVEN )
- WORKING PRESSURE ( P-2 ) : **17.2Mpa. ( 172BAR )**  
( GAS CONTROL TYPE : GAS REGULATOR CONTROL )
- MINIMUM GAS INLET PRESSURE : **0.35Mpa. ( 3.5BAR )**
- GAS BOOSTER M/K : **HASKEL ®**
- PRESSURE & FLOW RAGE ( P=BAR , FL=nl/min )

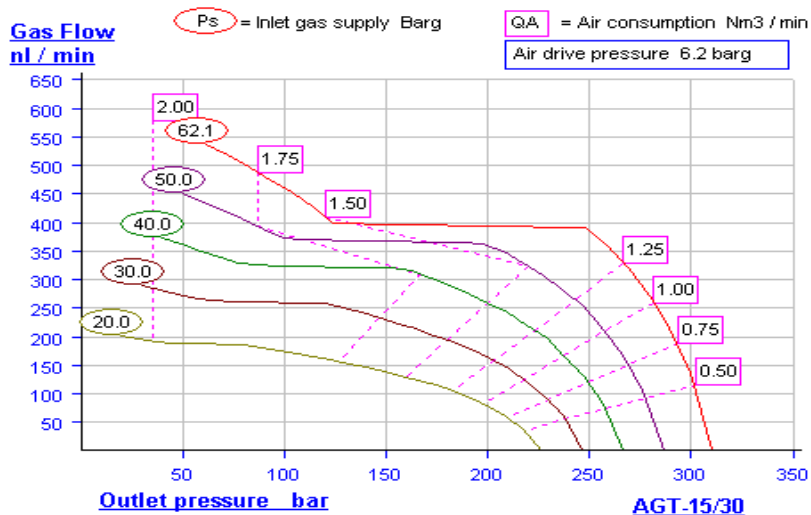

- STANDARD GAS RECEIVER : **500ml STANLESS STEEL**
- PRESSURE GAUGE : AIR = 100mm X 1Mpa TYPE = BD  
GAS INLET PRESSURE = 100mm X 15Mpa TYPE = BD  
GAS OUTLET PRESSURE ( P=1 ) = 100mm X 25Mpa TYPE = BD  
GAS OUTLET PRESSURE ( P=2 ) = 100mm X 25Mpa TYPE = BD