

BOOSTER DWG

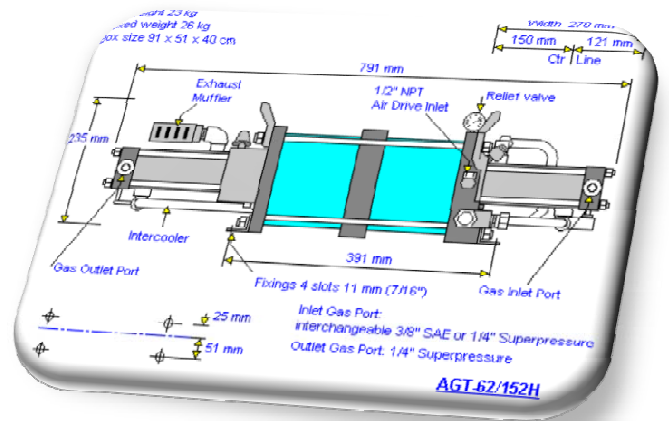

****** SPECIFICATION ******

- STANDARD GAS BOOSTER MODEL : **HAG-AGT-62/152H-P-T500**
- WORKING PRESSURE (P-1) : **70Mpa. (700BAR)**
(AIR DRIVEN PRESSURE = 0.6Mpa AIR DRIVEN)
- WORKING PRESSURE (P-2) : **69Mpa. (690BAR)**
(GAS CONTROL TYPE : GAS REGULATOR CONTROL)
- MINIMUM GAS INLET PRESSURE : **0.7Mpa. (7BAR)**
- GAS BOOSTER M/K : **HASKEL ®**
- PRESSURE & FLOW RAGE (P=BAR , FL=nl/min)

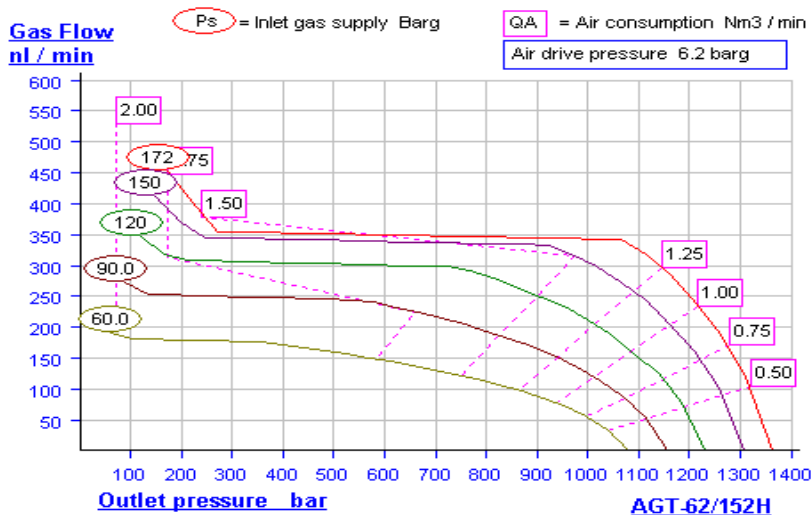

- STANDARD GAS RECEIVER : **500ml STANLESS STEEL**
- PRESSURE GAUGE : AIR = 100mm X 1Mpa TYPE = BD
GAS INLET PRESSURE = 100mm X 15Mpa TYPE = BD
GAS OUTLET PRESSURE (P=1) = 100mm X 100Mpa TYPE = BD
GAS OUTLET PRESSURE (P=2) = 100mm X 100Mpa TYPE = BD